



# HIRSCHMANN

A **BELDEN** BRAND

## Ethernet Enables The Smart Grid

by

### Bill Wotruba

Belden Industrial Solutions  
Director of Networking and  
Connectivity Products

The electrical power generation, transmission and distribution system has survived for decades with limited intelligence. But the emergence of independent power producers, green power sources and new regulatory regimes is making it imperative to add smarts to the grid.

The grid receives power from a variety of conventional and green power sources. The grid then distributes this power to industrial, commercial and residential consumers. Power flowing into the grid must be matched with power outflows as closely as possible on a real-time continuous basis.

When power inflows and outflows don't match, voltage fluctuations occur on the grid. Excess demand lowers voltages, eventually to problematic levels. Power storage can address part of the problem by temporarily boosting power supplied to the grid, but storage is both technically challenging and very expensive. A better approach is to match power flowing into and out of the grid based on real-time information and control systems.

These real-time information and systems necessarily rely on wired and wireless communication networks, and the de facto standard for these networks is Ethernet. Various Ethernet protocols and attendant hardware including switches, routers and connectors form the power grid communication backbone.

This white paper will first show how the electric utility landscape has changed over the past few decades, necessitating the smart grid. It will then be shown how Ethernet-based Supervisory Control and Data Acquisition (SCADA) systems can be used to monitor and control power flowing into and out of the grid. Finally, it will be shown how Ethernet-based SCADA systems can be used to match power inflows and outflows to keep the grid stable.

## Why the Grid Needs to Get Smart

1. Variability of solar and wind power
2. Independent power producers
3. Changing utility regulatory regimes
4. Pressure to reduce emissions
5. Difficulty building new facilities

### Controlling Generation

Scheduling power output from generating plants used to be relatively easy, and there was little or no need for real-time information. A central dispatcher simply estimated overall customer demand for a period stretching out for a few days, and then supplied this information to its wholly owned generating plants via a phone call.

The generating plants dutifully complied and ramped output up and down as required to meet scheduled demand needs. Certain units, typically larger coal-fired or nuclear plants, were designated as base load and typically ran at or near full power. Natural gas turbines were often used to deliver peaking power, and hydro units were used to handle shorter term fluctuations in demand. Because power generation was predictable and controllable, the system worked well.

A major change to the power generation landscape occurred with the emergence of Independent Power Producers (IPPs) in the U.S. during the 1980s. These IPPs weren't owned by the utility, but they were connected to the grid. For a variety of reasons, controlling power output from these IPPs was more difficult than with wholly owned generating stations.

IPPs want to run their facilities at maximum efficiency to lower generation costs and increase profits. These goals often are in direct conflict with the utility whose interest is controlling IPP output to match demand regardless of effects on efficiency. Reconciling these two often conflicting aims requires real-time information flows between the IPP and the utility. The utility must inform the IPP of its needs for power, and the IPP must let the utility know if it can accommodate those needs and if so to what extent.

Another big change to the power generation equation was the emergence of alternative energy sources, particularly wind and solar. Unlike conventional generation, the power produced by solar and especially by wind can vary over a wide range in an unpredictable fashion, upsetting the entire balance of power supplied to the grid.



# HIRSCHMANN

A BELDEN BRAND

Solar power in many instances has at least some positive correlation to demand, especially in a localized area. When the sun is shining, at least part of power demand rises, primarily due to increased air conditioning load. But wind power has at best no correlation to demand, and in some instances a decided and predictable negative correlation. "In California, wind power is least available when you most need it," says Peter Darbee, CEO of utility PG&E Corporation.

"So, some wind is good. But if you get above a certain percentage - which is probably 15 percent or less on wind alone - what happens is you have to back up that wind with natural gas-fired turbines so that it's reliable when you need it," adds Darbee (see reference 1, *San Francisco Chronicle* interview with Peter Darbee, CEO of PG&E Corp. in *San Francisco*).

Initially, the problem of variable generation from solar and wind was easily accommodated as these sources made up a very small percentage of power supplied to the grid. But as more and more solar and wind plants are built and connected to the grid, variable generation is becoming a huge issue, particularly with wind power.



Unlike conventional generation, the power produced by solar and especially by wind can vary over a wide range in an unpredictable fashion, upsetting the entire balance of power supplied to the grid.

## BPA Struggles with Wind Power

The Bonneville Power Administration (BPA) is a not-for-profit federal electric utility that markets more than a third of the electricity consumed in the U.S. Pacific Northwest. The power is produced by 31 federal hydro stations and one nuclear plant in the Northwest, and is sold to more than 140 Northwest utilities. BPA purchases power from seven wind projects and has more than 2,000 megawatts of wind interconnected to its transmission system. BPA operates a high-voltage transmission grid comprising more than 15,000 miles of lines and associated substations in Washington, Oregon, Idaho and Montana.

BPA faced this situation in 2009, a typical example of the vagaries of wind power (see reference 4, *Balancing swings in power from wind farms on the Bonneville Power Administration grid*). "In the space of one hour, electricity generated at wind farms in the eastern end of the Columbia River Gorge shot up by 1,000 megawatts. Less than an hour later, the wind power plummeted almost as much," relates Michael Giberson, an instructor and research associate with the Center for Energy Commerce in the Rawls College of Business at Texas Tech University.

To deal with the situation, a BPA dispatcher had to continually work with the region's hydro plants to ramp power up and down in inverse amounts to wind power fluctuations. Luckily, hydro power is used in abundance by BPA.

Hydro is one of the few large base load generating sources that can be safely ramped up and down quickly, typically by diverting water behind a dam from a power-producing turbine to a bypass. While diversion quickly reduces power output, it does waste energy by routing water stored behind a dam from a turbine to a bypass. The bottom line is that there's a high cost for accommodating wind power, so much so that BPA now imposes a wind integration rate surcharge of \$1.29 per kilowatt per month on wind generators (see reference 2, *BPA announces rate changes - Keeping rates low and facilitating wind development remain top priorities*).

As can be seen from this example, it's no longer sufficient to schedule generation days in advance. Instead, what's needed is a real-time information and control system to control and schedule generation. This system must also extend to demand, encompassing both ends of the smart grid.

## Monitoring and Controlling Demand

Because power generation was so easy to manage in the past, there was relatively little effort made to control power demand. The entire power generation, transmission and distribution system was simply sized to accommodate peak load. Demand peaks and valleys were relatively easy to predict, and conventional generation was scheduled to maintain a relatively close match between generation and demand.

Utilities were generally allowed to set rates based on a proscribed rate of return on their capital investments, so there was an incentive to build new power plants and accompanying transmission and distribution infrastructure. Permitting of these facilities took weeks or months at worst as public concern for plant emissions and other negative externalities wasn't as virulent as it is today.

Even with conditions favoring new construction, shaving peak demand was sometimes recognized as a profitable pursuit, and efforts were made along those lines. But typically, these efforts didn't require high-speed real-time control and information systems. Power to certain end users, particularly large industrial customers, was simply cut or reduced in return for price breaks – all based on long term contracts negotiated with the utility.

But today's utility landscape is vastly different. Regulations and public opinion now favor conservation and green generation over conventional generation and new infrastructure. Add in variable generation from solar power and especially wind power, and the generation-demand equation has changed radically. To balance generation with demand – a utility must either continually adjust generation, demand or both – all on a real-time basis.

It's often easier and less costly to control demand, even when generation can be quickly adjusted in real-time. Monitoring and control of demand requires sophisticated control systems that rely on a wealth of real-time information. Utilities use

## Wireless Controls Customer Demand

For many electric utilities, a smart metering system is the elusive goal that will allow real-time high speed monitoring and control of customer demand. Unfortunately, **such systems are fiendishly complex and expensive to install and support.** The ideal smart metering system would include high speed two-way communications between each meter and the utility command center. Real-time meter readings would provide demand information to the utility, and pricing information would be provided to customers. Customers would then control their demand based on pricing signals from the utility.

While there is no questioning the value of such a system, interim solutions that deliver a substantial part of the benefits at a fraction of the cost are already implemented and working. One such solution is a wireless communication network implemented by Southern California Edison (SCE) to control residential air conditioning loads (see reference 5, *A Too-Smart Solution*).

The A/C cycling program allows SCE to temporarily turn off residential air conditioner compressors during Southern California power emergencies. Participation is strictly voluntary, but customers receive credits of up to \$200 on their summer season electric bills. SCE's peak demand typically occurs between 2 p.m. and 6 p.m. during summer weekday afternoons. At 3,400 MW, peak residential air conditioning demand is about 16% of total summer weekday afternoon peak load, so there is substantial potential for peak demand reduction.

The wireless network and its attendant components constitute a system that is very simple, low cost and reliable. SCE installs a small wireless contactor outdoors near the A/C compressor, and powers the contactor from the compressor's 240-V AC power feed. The contactor interrupts the 24-V DC control signal from the in-home thermostat to the compressor. The installation takes about an hour, the technician doesn't need to enter the house and the resident doesn't need to be home. Wireless communications between SCE and each contactor are straightforward. Instead of the two-way high speed data link required by smart metering systems, all that's needed is a one-way low speed wireless radio signal to the contactor. "This VHF radio signal is transmitted to the contactors from SCE's grid control center via radio towers placed throughout the utility's service area," notes the referenced article. Unlike smart metering systems, no customer action is required.

The next step in smart metering systems will be more comprehensive than SCE's A/C cycling program, and it will probably rely on wireless Ethernet. Much of the cost of a smart metering network is installation of the two-way communications link between each smart meter and the utility command center. Hard wiring this link to each meter might be prohibitively expensive in many cases, but wireless could provide a solution. Each meter could be equipped with a wireless Ethernet communications port and radio, and the meter radio could be linked to a wireless hub. Reliance on wireless standards like 802.11 could keep costs down and insure compatibility.

Once information is wirelessly gathered from each meter, customers could be provided with this data via the Internet. A few such programs are already in place in the U.S. with more planned (see Reference 6, Naperville's energy use to get more intelligent), and most will rely on browser-based Ethernet access to real-time electricity use. Once customers see real-time consumption information, utilities hope they will take action to reduce usage, especially during peak demand periods. Pending approval by regulatory authorities, variable pricing could be implemented to further induce customers to cut use at critical times.

these control systems to make decisions and send information to their customers (see sidebar – *Wireless Controls Customer Demand*).

Information collected about current demand, and information disseminated to generators and consumers, both travel via

Ethernet networks. Parts of these networks are already in place at some utilities, but much more needs to be done.



## Substation Information

Real-time information concerning power flowing into and out of the grid is measured by utilities through monitoring of their transmission and distribution systems, specifically their substations. Substations are used by utilities to step up voltages from generation to transmission levels, and to step down voltages from transmission to distribution levels (see Figure 1).

A substation near a power plant steps up a generation voltage ranging from 11-22kV to a transmission voltage between 138 and 765kV. Substations close to use points then step down transmission voltages to distribution voltages ranging from 13.2kV to 69kV.

At substations, power measurements are typically made for a variety of purposes

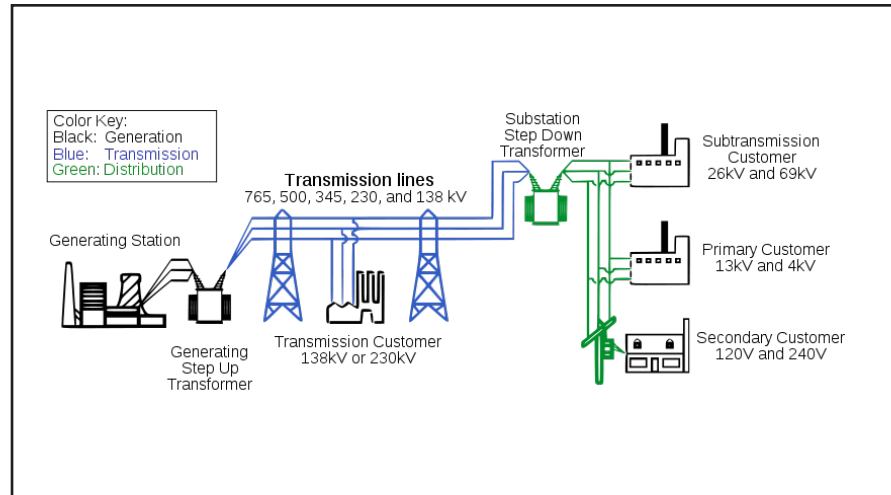

**Figure 1:** This diagram shows how power is typically distributed by a utility from generating stations to customers. Real-time power monitoring is typically performed at substations.

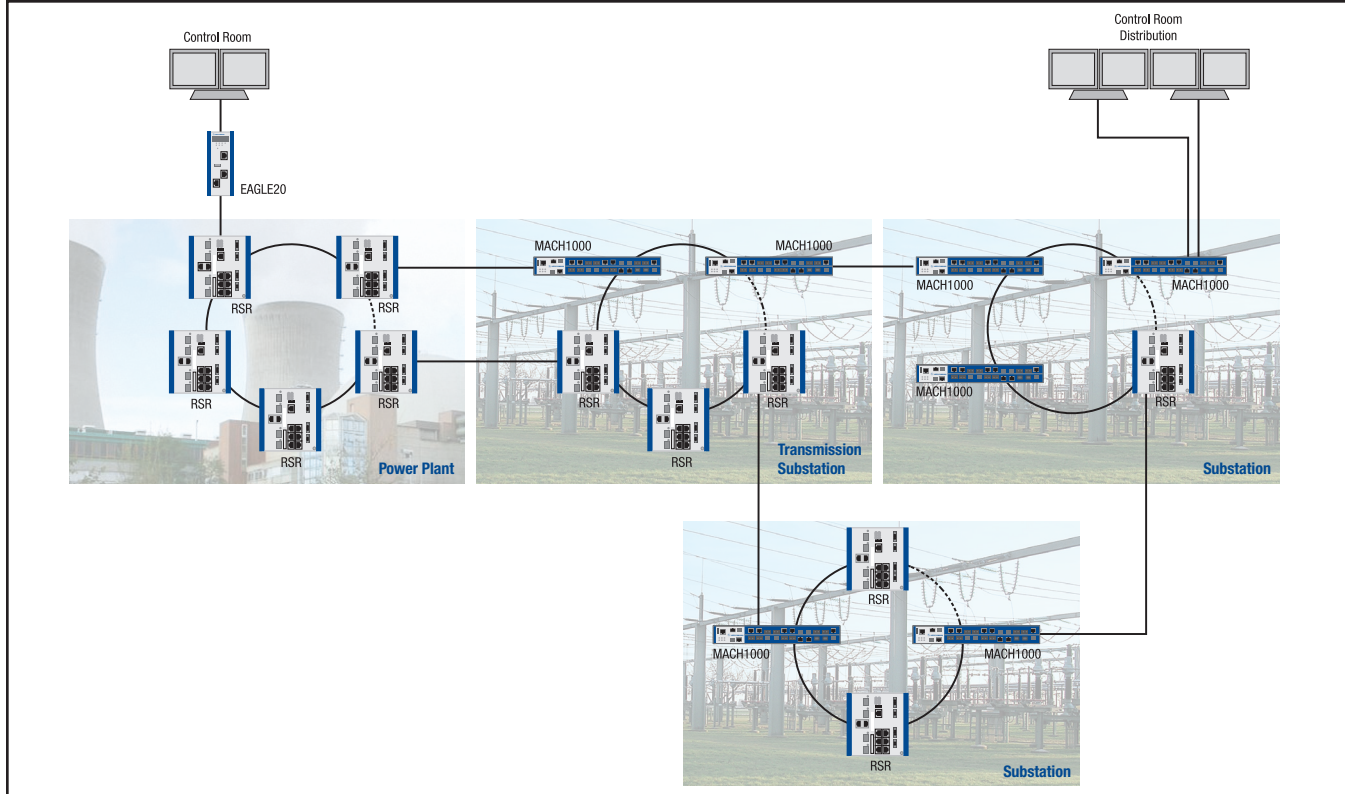

**Figure 2:** Management of communication among substation devices is typically accomplished by Ethernet switches installed at the substation. Although these switches can be managed or unmanaged, managed switches provide additional functionality critical to the robust deployment of Ethernet in substation automation applications.

including control and protection of substation equipment such as circuit breakers and transformers. These power measurements are made by various Ethernet-enabled devices such as protective relays and power monitors.

These devices are connected in a substation-wide Ethernet network to substation controllers, either general purpose programmable logic controllers (PLCs) or more specialized substation controllers. At some substations, controllers are also connected to a local industrial PC.

Ideally, all of these Ethernet-enabled devices will comply with the IEC 61850 Standard for Substation Automation (see reference 3, *Technical Overview and Benefits of the IEC*

*61850 Standard for Substation Automation*). Compliance with this standard standardizes and simplifies communication among these devices.

Management of communication among these Ethernet devices is typically accomplished by switches installed at the substation. Although these switches can be managed or unmanaged, managed switches provide additional functionality critical to the robust deployment of Ethernet in substation automation applications (see sidebar – *Managed Switches Improve Performance and Security*).

The substation environment in which these Ethernet switches must operate is often hostile, with wide variations in

temperature and humidity along with high vibration and electrical noise. Because of the mission critical nature of the substation automation network, high reliability is of the utmost concern. Compatibility with utility standards, specifically the IEC 61850 standard for substation automation, ensures reliability across a wide range of operating parameters.

In addition to managing communication of devices at the substation level, switches also enable communication between the substation and the utility dispatch centers via SCADA systems. These communications are via a virtual private network or some other means, and provide critical data that allows utilities to match generation with demand.

## Managed Switches Improve Performance and Security

All Ethernet switches perform two simple functions: store & forward switching and auto-negotiation. The first function is what separates switches from hubs, and the second function makes baud rate mismatches and crossover cables all but obsolete. Managed switches, however, provide additional functions critical to the robust deployment of Ethernet in applications like substation automation. Managed switches, oftentimes referred to as layer 3 switches, provide network administration functions including but not limited to filtering data flow, traffic prioritization, network diagnostics and access security.

Data filtering is usually based on the traffic type, broadcast or multi-cast, for example. Traffic prioritization is required when the network is simultaneously used for varied applications such as voice, video and automation data. Voice data requires a high priority or the conversation may be intermittent. Automation data can be prioritized on a port basis to ensure the highest level of repeatability and real-time response.

Alternately, prioritization of traffic can be accomplished by the segmentation of automation networks away from competing large bandwidth traffic like voice and video. Because of the enormous bandwidth available with modern Ethernet networks, this approach is most common.

Network diagnostic and access security are two features required in the design of a modern substation automation network. Diagnostics can be used to trigger an alarm based on bandwidth utilization, loss of communication or intermittent lost packets. Monitoring of lost packets is a very effective tool for preventative maintenance because an alarm can be activated before a catastrophic loss of communication. Communication losses are often due to cable degradation, frequently caused by rodent or water damage to buried cables. Lost packet monitoring can serve as an early warning, allowing maintenance to be performed on a scheduled rather than a reactive basis.

Access security can be accomplished in a number of ways using modern managed switch technology. A managed switch can be configured to turn off all unused ports, and activate an alarm when any device is plugged into an unused port. For security control of active ports, an access control list can be created and stored in the switch, controlling access based on either a MAC or an IP address. If access is attempted via an active port by a device not on the access control list, an alarm can be activated.

Managed switches can also be used to provide network redundancy, critical for high availability Ethernet applications like substation automation. Network redundancy provides alternate communications paths should a segment of the physical media be interrupted, either by failure or for maintenance purposes. Existing IEEE standard redundancy schemes such as Spanning Tree Protocol and Rapid Spanning Tree Protocol have limitations, so IEEE is now embarking on the development of a new standard called Managed Ring Protocol (MRP).

Redundant ring protocols have been part of the industrial Ethernet lexicon for many years. Hirschmann and Siemens introduced the first high speed ring protocol in 1990 and dubbed it Hlper Ring. Configuration consists of connecting the two designated ring ports on each switch to the ring, and then flipping a DIP switch on one of the switches to designate it as the redundancy manager.

Hlper Ring running at 100MBaud has been tested with 200 switches (a number of switches impossible with STP or RSTP) with a ring recovery time averaging 300ms and variability averaging less than ten percent. Fast Hlper Ring runs at 1GBaud, and has an average recovery time of 30ms. At 10GBaud, ring recovery is down to less than 10ms. This level of speed and consistency allows SCADA developers to use simple techniques to handle intermittent losses of communication without the loss of critical data.



## Balancing Generation and Demand

Information is gathered at substations and supplied to utility command centers via SCADA systems. This information allows a utility to continuously monitor power flowing into and out of the grid.

Monitoring of this information is the first step, the second is using the information to control and balance generation with demand. As previously related, control of generation is much harder in today's utility systems than in the past, primarily because of the emergence of IPPs and variable generation from green power sources.

An emerging trend is for utilities to pay power generators based not only on the amount of power supplied to the grid, but also on the predictability and reliability of supplied power. As detailed in Sidebar: BPA Struggles with Wind Power, some utilities are now imposing a wind integration rate surcharge to at least partially compensate the utility for the cost of coping with variable generation.

Such charges are very controversial, so much so that BPA had to reduce its originally proposed wind integration rate surcharge of \$2.72 per kilowatt per month to \$1.29

per kilowatt per month (*reference 2*). Part of this surcharge reduction was "due to actions taken by wind generators to reduce their use of BPA generation for reliability when wind power ramps up or down unexpectedly", but public pressure surely played a part.

IPPs and green power are here to stay, so it follows that utilities will focus most of their efforts on the demand side of the generation-demand equation. The best method of controlling demand relies on basic economics, namely raising prices to cut consumption.

A blunt instrument is to raise prices across the board, but a finer instrument is to only raise prices in times of high demand. Based on information collected from substations via Ethernet networks, utilities now have a real-time and high fidelity view of demand.

This information can be used to cut peak demand in one of two ways. First, customer demand can be cut by the utility to individual customers based on pre-existing agreements. Such agreements have long been in place with larger industrial customers, and newer technologies are now making it practical to extend these agreements to smaller industrial,

to commercial and even to residential customers (*see sidebar – Wireless Controls Customer Demand*).

As with substation-based SCADA systems, Ethernet technologies will make these customer demand systems viable. Wired and wireless Ethernet will be used to collect data from smart meters via wide area Ethernet networks.

Once the data is collected, data will be delivered to customers in one of two ways. For customers with ready access to a PC with a high bandwidth Internet connection, browser-based access to their on-line real time usage and pricing will be provided. For customers without such access or for customers that prefer a separate power usage display, a device will be provided that shows real-time usage and pricing. By adjusting prices, utilities intend for customers to control demand.

## References:

1. San Francisco Chronicle interview with Peter Darbee, CEO of PG&E Corp. in San Francisco, <http://www.sfgate.com/cgi-bin/article.cgi?=/c/a/2007/11/18/BU80TD6ER.DTL>
2. BPA announces rate changes - Keeping rates low and facilitating wind development remain top priorities, <http://www.piersystem.com/go/doc/1582/292435/>
3. Technical Overview and Benefits of the IEC 61850 Standard for Substation Automation, [http://www.sisconet.com/downloads/IEC61850\\_Overview\\_and\\_Benefits\\_Paper\\_General.pdf](http://www.sisconet.com/downloads/IEC61850_Overview_and_Benefits_Paper_General.pdf)
4. Balancing swings in power from wind farms on the Bonneville Power Administration grid, <http://knowledgeproblem.com/2009/07/28/balancing-swings-in-power-from-wind-farms-on-the-bonneville-power-administration-grid/>
5. A Too-Smart Solution?, <http://www.controlglobal.com/articles/2007/237.html>
6. Naperville's energy use to get more intelligent, [http://www.suburbanchicagonews.com/napervillesun/news/1941266.Naperville-intelligent-energy-use\\_na121609.article](http://www.suburbanchicagonews.com/napervillesun/news/1941266.Naperville-intelligent-energy-use_na121609.article)