



Choosing a Variable Frequency Drive or Soft Starter based on your application need

Overview

When accelerating an AC motor to full speed using a full voltage connection, a large inrush current may be required. Additionally, the torque of the AC motor is mostly uncontrolled and can shock the connected equipment, potentially causing damage. Variable Frequency Drives and Reduced Voltage Soft Starters and can both be used to reduce inrush currents and limit torque; thereby protecting expensive equipment and extending the life of the motor and coupling devices. Choosing between a variable frequency drive and soft starter often depends on the type of application, the mechanical system requirements, and cost (both for initial installation and over the lifecycle of the system).



Soft starters

A reduced voltage soft starter helps protect the motor and connected equipment from damage by controlling the terminal voltage. This limits the initial inrush of current and reduces the mechanical shock associated with motor startup and provides a more gradual ramp up to full speed. Soft Starters are also beneficial to electrical systems with limited current capacity when using a soft starter for motor starting to limit the inrush current. By gradually increasing the motor terminal voltage the soft starter produces a more regulated motor acceleration up to full speed. Soft starters are also capable of providing a gradual ramp to stop where sudden stopping may create problems in the connected equipment.



Applications

Soft starters are used in applications where:

- Speed ramping and torque control are desired when starting or stopping
- High inrush currents associated with starting a large motor need to be limited to avoid supply network issues or penalty charges
- A gradual controlled starting is needed to avoid torque spikes and tension in the mechanical system associated with normal equipment startup (e.g., conveyors, belt-driven systems, gears, couplings, etc.)
- Avoiding pressure surges or 'hammering' in piping systems when fluid changes speed too rapidly



How does a soft starter work?

Solid state soft starters use semiconductor devices to temporarily reduce the motor terminal voltage. This provides control of the motor current to reduce inrush and limit shaft torque. The control is based on controlling the motor terminal voltage on two or three phases. By limiting the voltage to the motor, a reduced torque is provided to start the load more gradually.

Benefits of choosing a soft starter

Soft starters are often the more economical choice for applications that only require speed and torque control during motor startup. Additionally, they are often the ideal solution for applications where space is a concern, as they usually take up less space than comparable variable frequency drives.

Simplified One-line of a Solid State Reduced Voltage Soft Starter

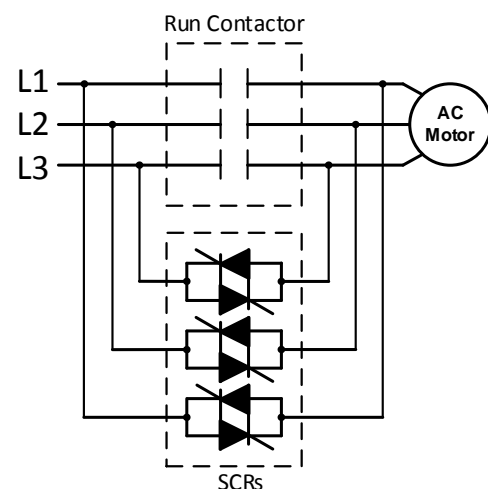

Figure 1. Solid State Soft Starter Main Circuit Diagram

Variable frequency drives

A variable frequency drive (VFD) is a motor control device that protects and controls the speed of an AC induction motor. A VFD can control the speed of the motor during the start and stop cycle, as well as throughout the run cycle. Variable frequency drives are also referred to as adjustable frequency drives (AFD).



Applications

Variable frequency drives are used in applications where:

- Complete speed control is required
- Energy savings is a goal
- Custom control is needed

How do VFDs work?

Variable frequency drives convert constant frequency and voltage input power to adjustable frequency and voltage source for controlling the speed of AC induction motors. The frequency of the power applied to an AC motor determines the motor speed, based on the following equation:

$$N = \frac{120f}{p}$$

Where:

N = speed (rpm)

f = frequency (Hz)

p = number of motor poles

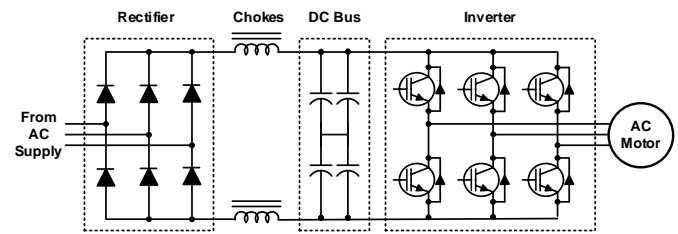

Figure 2. Variable Frequency Drive Main Circuit Diagram

AC supply: Comes from the facility power network (typically 208V, 230V, 480V, 575V, 690V / 60 Hz AC)

Rectifier: Converts (rectifies) network AC power to DC power

Chokes and DC bus: Work together to smooth the rectified DC power and provide clean, DC power to the inverter with low ripple content

Inverter: Uses DC power from the DC bus and chokes to invert an output that resembles sine wave AC power using a pulse width modulation (PWM) technique

Pulse width modulation: Switches the inverter semiconductors in varying widths and times that, when averaged, create a sine waveform

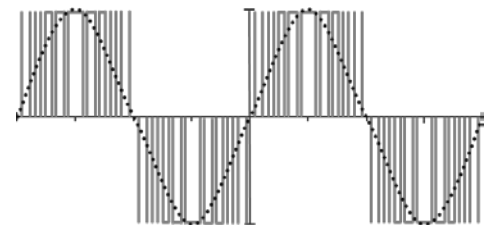

Figure 2. Pulse width modulated waveform



Benefits of using a variable frequency drive

Performance

- Fully adjustable speed (pumps, conveyors, fans, etc.)
- Controlled starting, stopping, and acceleration
- Dynamic torque control
- Provides smooth motion for applications such as elevators and escalators
- Maintains speed of equipment, making drives ideal for manufacturing equipment and industrial equipment such as mixers, grinders, and crushers

Versatility

- Self-diagnostics and communications
- Advanced overload protection
- PLC-like functionality and software programming
- Digital inputs/outputs (DI/DO)
- Analog inputs/outputs (AI/AO)
- Relay outputs

Energy savings

- Reduces peak energy demand
- Reduces power when not required

Energy savings

Variable frequency drives offer the greatest energy savings for fans and pumps. The adjustable flow method changes the flow curve and drastically reduces power requirements. Centrifugal equipment (e.g., fans, pumps, and compressors) follow a general set of speed affinity laws. The affinity laws define the relationship between a set of variables. In this case, the correlation is the pressure change in relation to speed or flow, and the power change in relation to flow. Based on the affinity laws, flow changes linearly with speed while pressure is proportional to the square of speed or flow. The power required is proportional to the cube of the

speed or flow. The latter is most important, because if the motor speed drops, the power drops by the cube.

For this example, a motor is operated at 80 percent of the rated speed. This value can be inserted into the affinity laws formula to calculate the power at this new speed:

$$\frac{Flow_1}{Flow_2} = \frac{RPM_1}{RPM_2} \quad \frac{Head_1}{Head_2} = \left(\frac{RPM_1}{RPM_2}\right)^2$$

$$\frac{Power_1}{Power_2} = \left(\frac{RPM_1}{RPM_2}\right)^3$$

$$80\%^3 \text{ or } 0.8^3 = 51.2 \text{ percent}$$

Therefore, the power required to operate the fan at 80 percent speed is half the rated power.

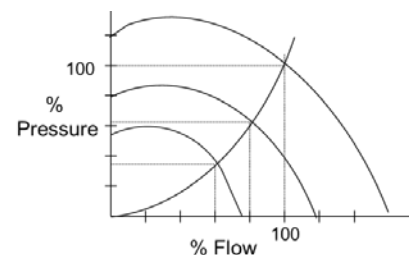

Figure 3. Flow and Pressure Relationship

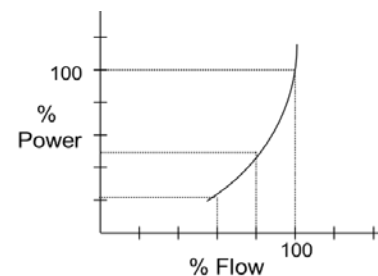

Figure 4. Flow and Power Relationship

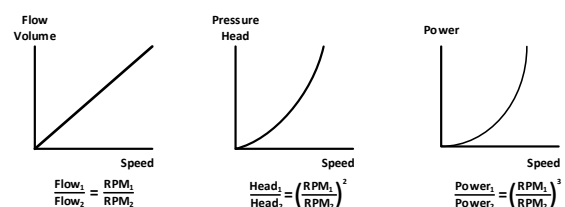

Figure 5. Affinity laws



Selecting the correct motor control equipment for your needs

Choosing a soft starter or variable frequency drive often depends on your application. Soft starters are smaller and less expensive when compared with variable frequency drives, especially in larger horsepower applications. Larger variable frequency drives take up more space and are usually more expensive than soft starters.

However, while a variable frequency drive can be more expensive initially, they can provide energy savings of up to 50 percent, therefore providing operating cost savings over the life of the equipment for a lower total cost of ownership.

Speed control is another advantage of a variable frequency drive, because they offer consistent acceleration time throughout the entire operating range of the motor, not just during startup. Variable frequency drives can also provide more flexible functionality than soft starters offer, including digital diagnostic information.

It's important to note that variable frequency drives can initially cost two to three times more than a soft starter. Therefore, if constant acceleration and torque control is not necessary, and your application only requires current limiting during startup, a soft starter may be a more cost effective solution for your needs.

Dave Mintzlaff is Product Manager for Low Voltage Drives and Soft Starters at WEG Electric Corp.

For more information on this topic contact:

WEG Electric Corporation
6655 Sugarloaf Parkway
Duluth, GA 30097 USA
www.weg.net/us